

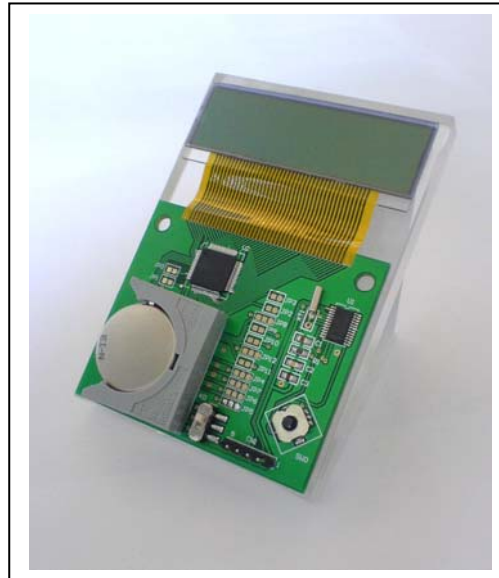

EM6110 DemoKit User's Manual



Description

The EMDB6110+ is a standalone demokit based on LCD segment drivers/controller EM6110. This allows an easy evaluation of the EM6110.

A microcontroller EM6812 is used to send, receive commands and data through I2C bus.

This demokit is delivered with pre-programmed firmware on EM6812. The firmware runs several demos to show EM6110 performance.

Different configurations can be set by jumpers (I2C address, Serial mode, power supply, ...)

A joystick is used to start and set up the demo show.

The EM6110 demokit contains LCD segments glass, PCB with EM6110 and EM6812.

All of the latest versions of documentation are published on EM Microelectronic website www.emmicroelectronic.com

Features

- LCD segments glass (STN Grey Reflective Positive Mode)
- 4 axis joystick with push button
- 3V Lithium battery
- 32 kHz oscillator
- 5 pin connector for microcontroller programming
- PCB equipped with EM6812 TSSOP24 and EM6110 TQFP64
- All Commons and segments are outputted on connector
- ROHS compliant

Ordering Information

Description	Part Number
EM6110 Demo kit	EMDB6110+



EMDB6110

Quick Start

Joystick : Down Up Left Right

EM6110

CHRONO 0000 Start : Stop :

JOYS1 BAR

JOYS2 ICON

JOYS3 XY

V100

Settings

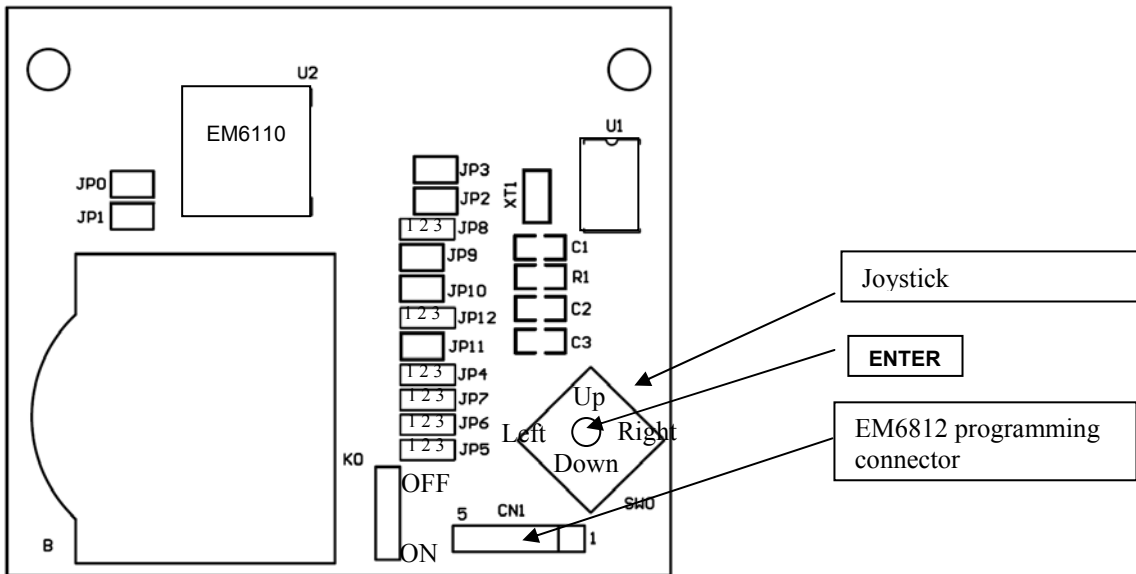

Jumper		Description		Default
		Open	Close	
JP0	VLCD	VLCD can be connected to an external power supply	VLCD is connected to the 3V battery	Close
JP1	VDD	Vdd (EM6110 Logic) can be connected to an external power supply	VDD (EM6110) is connected to the 3V battery	Close
JP2	VSS	Vss (EM6110) can be connected to an external power supply	Vss (EM6110) is connected to the battery ground	Close
JP3	V4	V4 (EM6110) can be connected to an external power supply	V4 is connected to the ground	Close
JP9	STR/A2	STR (EM6110) can be connected to an external host	STR is connected to the EM6812 microcontroller	Close
JP10	CLK	CLK (EM6110) can be connected to an external host	CLK is connected to the EM6812 microcontroller	Close
JP11	DI	DI (EM6110) can be connected to an external host	DI is connected to the EM6812 microcontroller	Close

Jumper		Description / Jumper position		Default
		1-2	2-3	
JP4	SFR	FR External	FR Internal	2-3
JP5	OPT0	I2C mode (Refer to datasheet)	(Refer to datasheet)	1-2
JP6	OPT1	I2C mode (Refer to datasheet)	(Refer to datasheet)	1-2
JP7	SSYN	Synchronisation Signal: SYN is input	Synchronisation Signal: SYN is output	2-3
JP8	COLN/A1	I2C Address: A1=1	I2C Address: A1=0	2-3
JP12	DO/A0	I2C Address: A0=1	I2C Address: A0=0	2-3

LCD Mapping

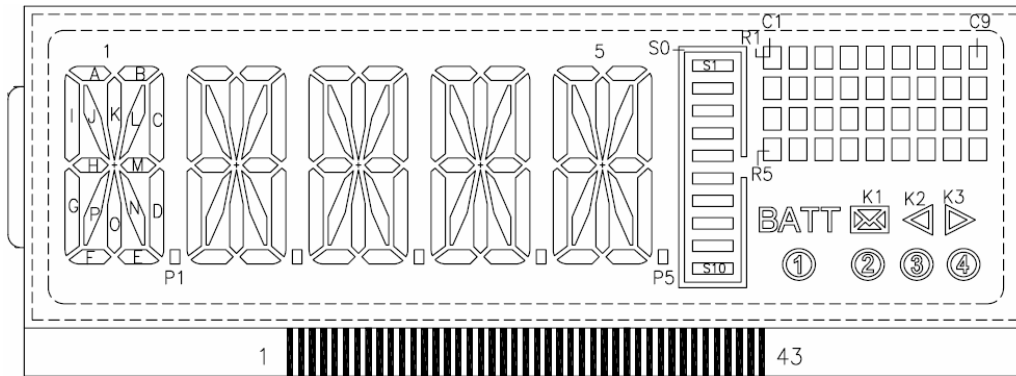

Pin n°	EM6110 n°	COM1	COM2	COM3	COM4
1	COM1	COM1			
2	COM2		COM2		
3	COM3			COM3	
4	COM4				COM4
5	S1	1A	1I	1G	-
6	S2	1J	1H	1P	-
7	S3	1K	1L	1O	1F
8	S4	-	1M	1N	1E
9	S5	1B	1C	1D	P1
10	S6	2A	2I	2G	-
11	S7	2J	2H	2P	-
12	S8	2K	2L	2O	2F
13	S9	-	2M	2N	2E
14	S10	2B	2C	2D	P2
15	S11	3A	3I	3G	-
16	S12	3J	3H	3P	-
17	S13	3K	3L	3O	3F
18	S14	-	3M	3N	3E
19	S15	3B	3C	3D	P3
20	S16	4A	4I	4G	-
21	S17	4J	4H	4P	-
22	S18	4K	4L	4O	4F

Pin n°	EM6110 n°	COM1	COM2	COM3	COM4
23	S19	-	4M	4N	4E
24	S20	4B	4C	4D	P4
25	S21	5A	5I	5G	-
26	S22	5J	5H	5P	-
27	S23	5K	5L	5O	5F
28	S24	-	5M	5N	5E
29	S25	5B	5C	5D	P5
30	S26	-	S10	S1	S0
31	S27	S6	S7	S8	S9
32	S28	S5	S4	S3	S2
33	S29	1	2	K1	BATT
34	S30	3	4	K3	K2
35	S31	R1C9	R2C9	R3C9	R4C9
36	S32	R1C8	R2C8	R3C8	R4C8
37	S33	R1C7	R2C7	R3C7	R4C7
38	S34	R1C6	R2C6	R3C6	R4C6
39	S35	R1C5	R2C5	R3C5	R4C5
40	S36	R1C4	R2C4	R3C4	R4C4
41	S37	R1C3	R2C3	R3C3	R4C3
42	S38	R1C2	R2C2	R3C2	R4C2
43	S39	R1C1	R2C1	R3C1	R4C1



EMDB6110

Mechanical Dimension

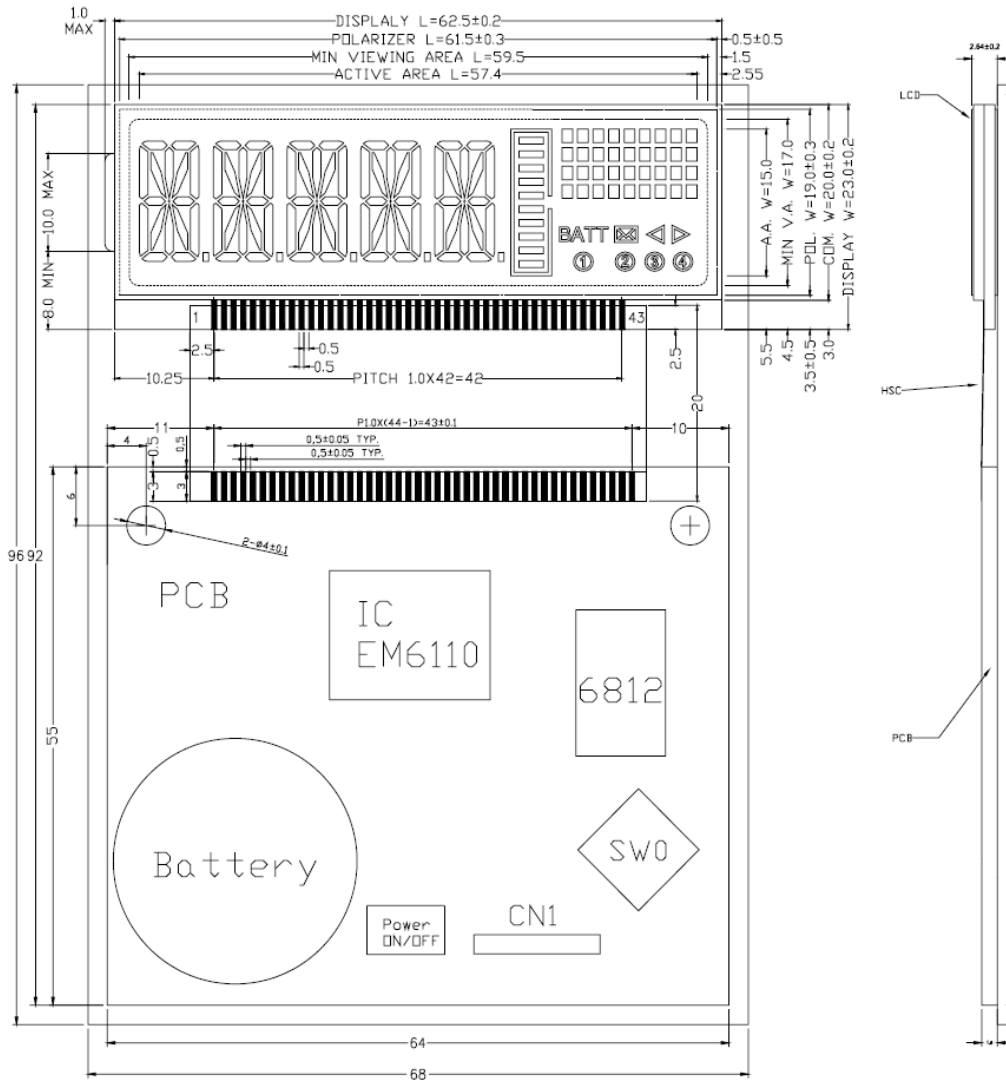

Bill of Materials

N°	Description	Reference
U1	8 bit Microcontroller	EM6812 TSSP24
U2	LCD segment drivers/controller	EM6110 TQFP64
B	Renata Lithium Battery	CR2450N
S0	Renata Battery holder	NL5077
SW0	Joystick + Push button	ALPS SKRHABE010
R1	Resistor	1K Ohms
XT	Crystal 32kHz	Microcrystal
C1	Capacitor	470nF
C2	Capacitor	100nF
C3	Capacitor	1uF
K0	ON/OFF Switch	
JP0-JP12	Jumpers	



Programming

EMPB2 programmer

EMPB2 Connector	CN1	Description
1	1	VDD
6	2	PB7
8	3	PB5
7	4	VSS
10	5	TEST

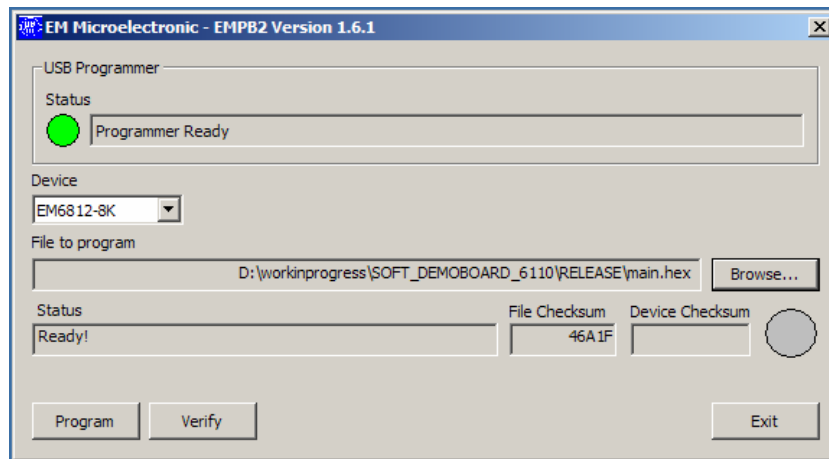

- 1- Connect USB cable on PC
- 2- Connect Programming cable on target (CN1)
- 3- Power ON (K0)
- 4- Execute EMPB2
- 5- Choose EM6812-8K microcontroller
- 6- Browse main.hex
- 7- Program Microcontroller
- 8- Remove Programming cable
- 9- Power OFF
- 10- Power ON

EM Microelectronic-Marín SA (EM) makes no warranty for the use of its products, other than those expressly contained in the Company's standard warranty which is detailed in EM's General Terms of Sale located on the Company's web site. EM assumes no responsibility for any errors which may appear in this document, reserves the right to change devices or specifications detailed herein at any time without notice, and does not make any commitment to update the information contained herein. No licenses to patents or other intellectual property of EM are granted in connection with the sale of EM products, expressly or by implications. EM's products are not authorized for use as components in life support devices or systems.