



Low Power Crystal Oscillator Circuit 32.768 kHz

Description

EM7604 is an advanced low power CMOS circuit intended to be used together with a 32.768 kHz tuning fork crystal as a low frequency clock oscillator. Except the crystal, no other external components are required. The device combines excellent oscillator stability with very low power consumption. It is guaranteed over a very wide supply voltage and temperature range. In order to achieve a high frequency accuracy, the matched crystals should have a ± 20 ppm tolerance or tighter. The output frequency is synchronized with signal on input Clock Enable CLKEN. The frequency output CLKOUT is enabled by connecting Clock Enable pin CLKEN to V_{DD}. Connecting CLKEN to V_{SS}, disables the frequency and the output CLKOUT is at Low State. Offered in a small SOT23-6 package, the EM7604 is a completely lead free product.

Features

- Very low power consumption: typ. 300nA
- Wide supply voltage range: 1.2V to 5.5V
- Operating temperature range: -40°C to +125°C.
- On chip integrated oscillation capacitors: C_L = 8pF
- Very tight frequency tolerance
- Excellent oscillator stability: 0.2 ppm/V
- Synchronised output after Enable/Disable
- Compatibility with crystals having high series resistance
- Small SOT23-6 package
- 100% lead free, RoHS - compliant

Typical Applications

- General purpose clock generator for digital systems
- Clock drivers for Real Time Clocks
- Timekeeping in network servers and computers
- Data logger
- Electricity, gas and water metering
- Portable field communication
- Mobile phone
- Solution for problems with embedded quartz oscillators

Pin Connection Top View

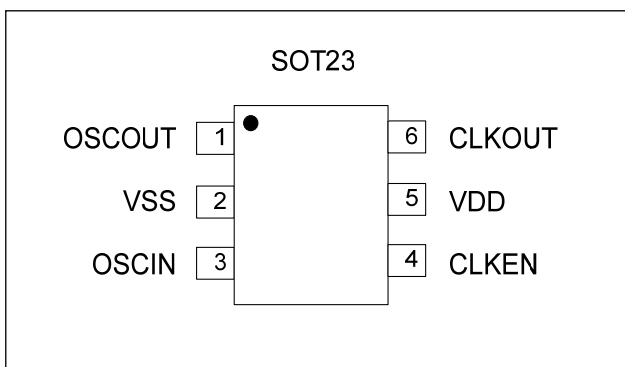

Pin	Connection	Assignment
1	OSCOUT	Oscillator Output
2	VSS	Negative Supply Voltage
3	OSCIN	Oscillator Input
4	CLKEN	Output Enable
5	VDD	Positive Supply Voltage
6	CLKOUT	Frequency Output

Block Diagram

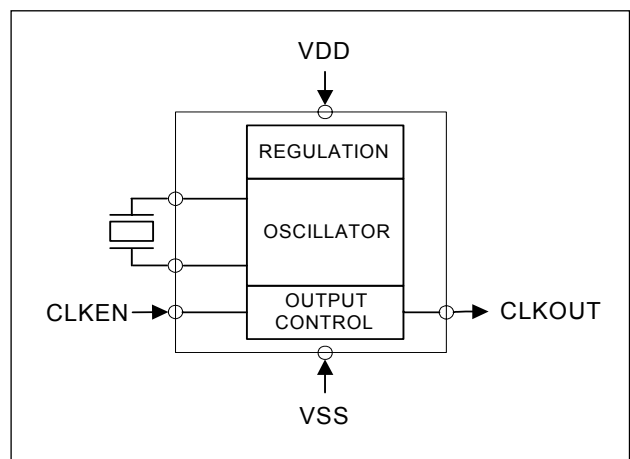



EM7604

Absolute Maximum Ratings

Parameter	Symbol	Conditions
Voltage at V_{DD} to V_{SS}	V_{DD}	-0.3V to +6V
Minimum voltage	V_{MIN}	$V_{SS} - 0.3V$
Maximum voltage	V_{MAX}	$V_{DD} + 0.3V$
Storage temperature range	T_{STG}	-55°C to +150°C
Maximum soldering	T_{Smax}	260°C x 20s

Stresses above these listed maximum ratings may cause permanent damages to the device. Exposure beyond specified operating conditions may affect device reliability or cause malfunction.

Handling Procedures

This device has built-in protection against high static voltages or electric fields; however, anti-static precautions must be taken as for any other CMOS component. Unless otherwise specified, proper operation can only occur when all terminal voltages are kept within the voltage range. Unused inputs must always be tied to a defined logic voltage level.

Operating Conditions

Parameter	Symbol	Min	Max	Unit
Supply voltage	V_{DD}	1.2	5.5	V
Operating temperature	T_A	-40	+125	°C
Quartz serial resistance	R_S		110	kΩ

Electrical Characteristics

$V_{DD} = 3.0V$; $V_{SS} = 0V$; $T_A = 25^\circ C$; $R_S = 60k\Omega$; unless otherwise specified.

Parameter	Symbol	Conditions	Min	Typ	Max	Unit
Supply						
Supply voltage range	V_{DD}		1.2	3.0	5.5	V
Mean current consumption (Note 1)	I_{DD}	$V_{DD} = 5.0V$, CLKEN at V_{SS}		300	550	nA
		$V_{DD} = 3.0V$, CLKEN at V_{SS}		250	500	nA
		$V_{DD} = 5.0V$, CLKEN at V_{SS} , $T_A = -40$ to $+85^\circ C$		750	1000	nA
		$V_{DD} = 3.0V$, CLKEN at V_{SS} , $T_A = -40$ to $+85^\circ C$		650	900	nA
Oscillator						
Output frequency	f_O			32.768		kHz
Starting voltage	V_{ST}	Within 3 seconds	1.2			V
Start-up time	T_{ST}			0.4	0.8	sec
Voltage coefficient	$\Delta f/f_O * \Delta V_{DD}$	$1.5V \leq V_{DD} \leq 5.5V$		± 0.2	± 2	ppm/V
Output driver CLKOUT						
Output voltage high	V_{OH}	$I_{OH} = -1.0mA$	$V_{DD} - 0.4$			V
Output voltage low	V_{OL}	$I_{OL} = 1.0mA$			$V_{SS} + 0.4$	V
Output rise time	t_r	$C_L = 15pF$, 10% to 90% V_{DD}		70	100	ns
Output fall time	t_f	$C_L = 15pF$, 10% to 90% V_{DD}		70	100	ns
Duty cycle			49	50	51	%
Output Enable CLKEN						
Input voltage low	V_{IL}		V_{SS}		$0.2 \times V_{DD}$	V
Input voltage high	V_{IH}		$0.8 \times V_{DD}$		V_{DD}	V

Note 1: The current consumption when the output clock is enabled (CLKEN pin at V_{DD}) is a function of the load capacitance on the CLKOUT pin, the output frequency $f_{OUT} = 32768Hz$ and the supply voltage V_{DD} . The additional consumption for a given load can be calculated from: $\Delta I_{DD} = C_{LOAD} \times V_{DD} \times f_{OUT}$.



Timing Waveforms

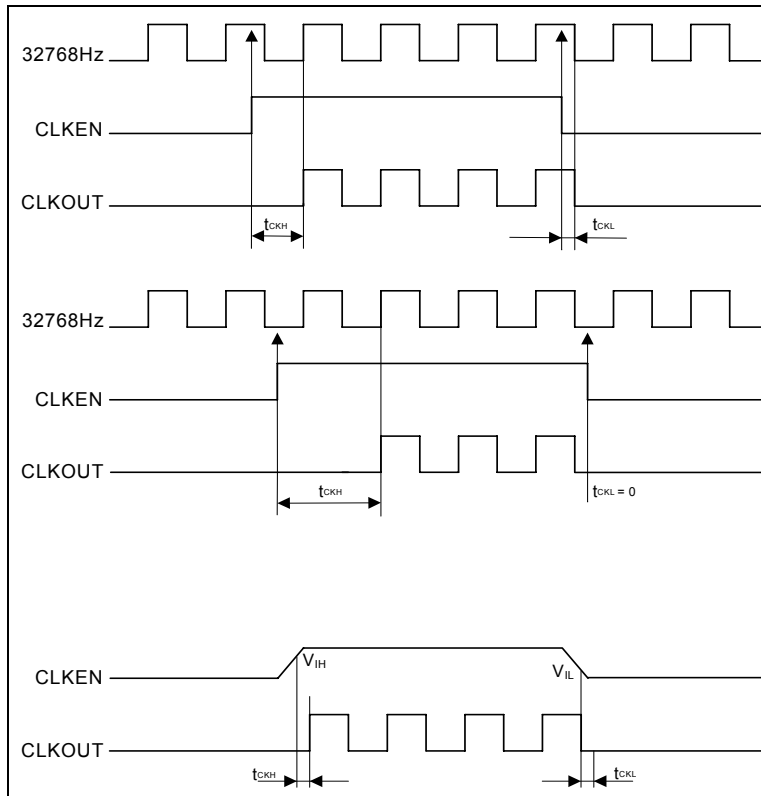

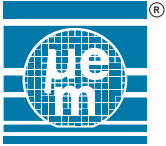

EM7604

Package Information:

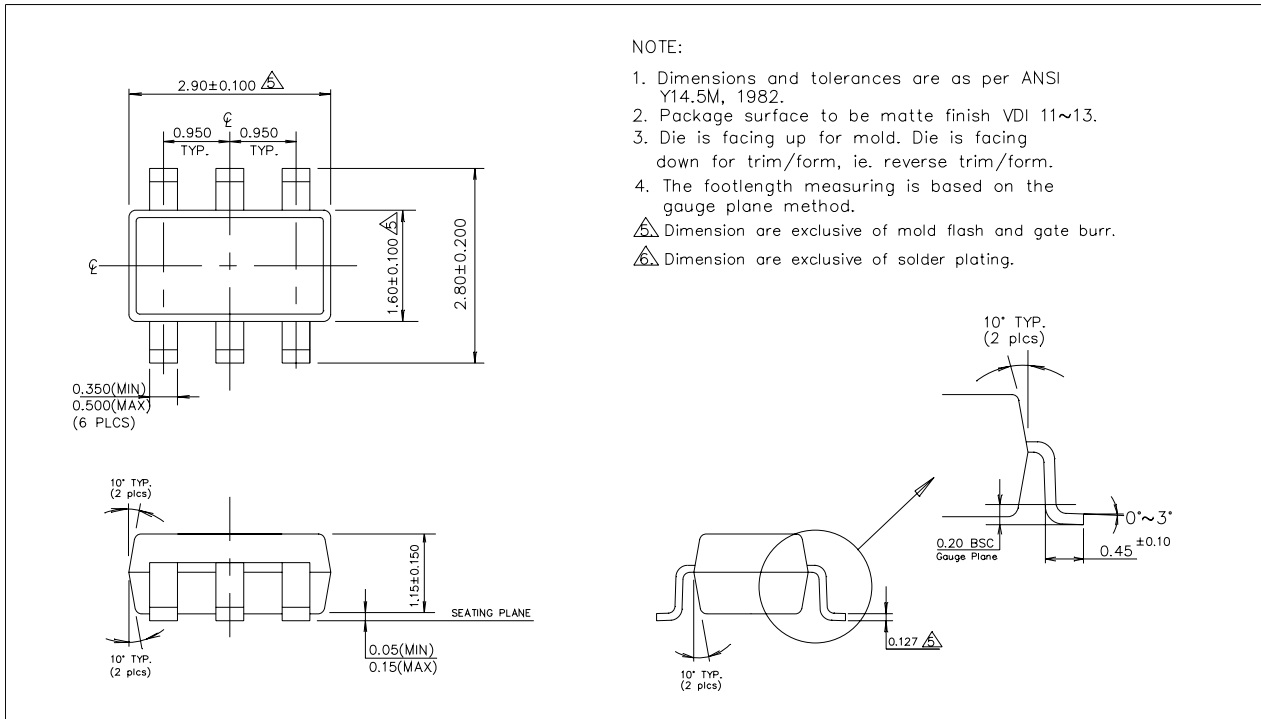

Ordering Information

Part Number	Version	Package Type	Top Side Marking	Delivery Form
EM7604V00SP6B+	V00	SOT23-6	OVXY	Tape & Reel

Contact EM Microelectronic for availability in chip form or in other packages.

XY characters of the Top marking are used for the lot traceability.

EM Microelectronic-Marín SA (EM) makes no warranty for the use of its products, other than those expressly contained in the Company's standard warranty which is detailed in EM's General Terms of Sale located on the Company's web site. EM assumes no responsibility for any errors which may appear in this document, reserves the right to change devices or specifications detailed herein at any time without notice, and does not make any commitment to update the information contained herein. No licenses to patents or other intellectual property of EM are granted in connection with the sale of EM products, expressly or by implications. EM's products are not authorized for use as components in life support devices or systems.